

FTTH Fiber optic distribution box FODB-16H

Product Information

Fiber To The Home optical distribution box is designed to terminated feeding fiber optic cables and connect the last mile cables as fiber optic patch cords, pigtails and FTTH drop cables. This fiber optical distribution box is made of high quality UV resistant thermoplastic, reinforced by fiberglass material. Soft rubber gel sealing provide IP68 dust and water protection, suitable for outdoor application.

Features

- ❖ 16+2 SC of adapters
- ❖ 4 of PLC blockless splitters
- ❖ Soft rubber protection
- ❖ IP-68

Application

- ❖ FTTH, FTTB, FTTx
- ❖ Telecommunication Network
- ❖ Local Area Network
- ❖ CATV
- ❖ PON



Technical Specification

Model No.	No. of entry ports	No. of exit ports	Max. Capacity	PLC Splitter
FODB-16H	2 of cable inputs 15-5 mm	1 inlet port, 16 drop cable slots	48 + 32 fibers - two splicing capacity	4 PLC

Picture

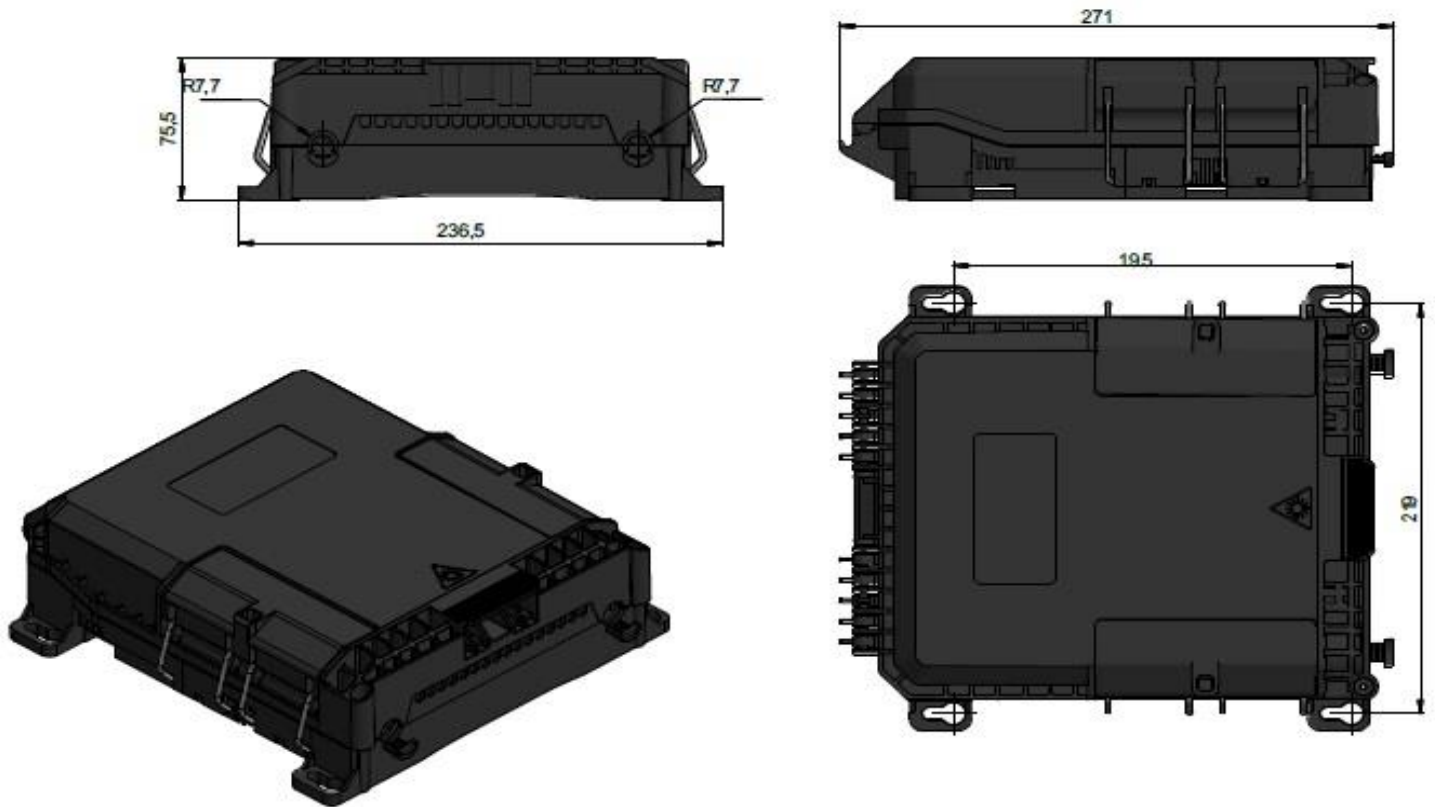

KST Ltd.

Address: 357 Slivnitsa Blvd.,
Sofia, Bulgaria

Tel: +359 2 927-72-56
Fax: +359 2 927-00-14

Web: www.kst-bg.com
E-mail: sales@kst-bg.com